

SPEEDY GLOVE

AUTOMATIC PORTABLE GLOVE INTEGRITY TESTER



**VPHP
COMPATIBLE**

**WI-FI
READY**

**RFID
TECHNOLOGY**

**WIDE
TOUCH-SCREEN**



 **COMECER**
AN **ATS** COMPANY

SPEEDY GLOVE

AUTOMATIC PORTABLE GLOVE INTEGRITY TESTER

Speedy Glove is a battery-powered portable device that performs integrity tests on gloves installed on isolators or RABS where a strict separation between the isolated area and the external environment is required. The system performs pressure decay integrity tests that comply with the requirements of ISO 14644-7 Annex E.5.

Speedy Glove is compatible with all currently available glove flanges, is fitted with a touch-screen that can be used with gloves, and is extremely fast in carrying out the test (**up to 30% faster than the market standard**).





VPHP
COMPATIBLE



RFID
TECHNOLOGY



WI-FI
READY



COMPLETE
TOUCH-SCREEN



EXTREMELY FAST OPERATION

HIGHEST ACCURACY

COMPLETE TOUCH-SCREEN

RFID TECHNOLOGY

WI-FI READY

VPHP COMPATIBLE

CGMP COMPLIANCE..



FEATURES AND BENEFITS

Main features Speedy Glove

- Fast rapid inflation system
- Adapters with airtight connection system for all standard or custom glove flanges on the market Full touch-screen HMI panel for execution of the tests, control of the parameters and functionality, management of the test history and calibration check of the device
- No pneumatic connections needed
- Compatibility with VPHP for introduction into the aseptic area and performance of the test from the inside of the isolator or RABs
- Up to 8 hours in stand by mode
- Wireless connection to the Speedy Glove Management System or to the facility network
- Equipped with RFID technology for automatic recognition of flange and adaptor
- Traceability of parameters and recipes, users and complete audit trail in compliance with 21CFR Part 11
- Procedures for QC and calibration check of the pressure sensor integrated in the system
- IOQ and PQ qualification available on request

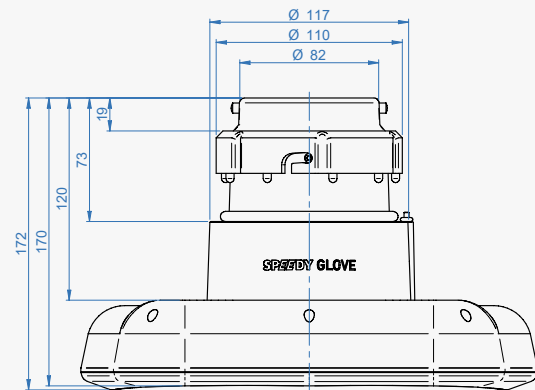
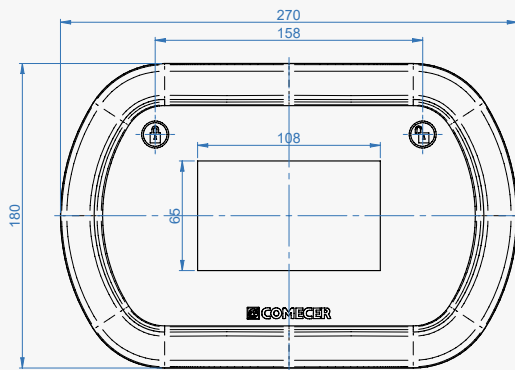

2024-12 | All rights reserved | BR_SPEEDY-GLOVE_RB_ENG_MKT000032

WE ARE YOUR PARTNER FOR LIFE

HEADQUARTERS

COMECER S.p.A.

Via Maestri del Lavoro, 90
48014 - Castel Bolognese (RA) - Italy
t: +39 0546 656375 - f: +39 0546 656353
comecer@comecer.com - www.comecer.com



Legal manufacturer:
Comecer Netherlands B.V.
Madame Curieweg 1
8501 XC Joure - NL

SUBSIDIARY COMPANIES

COMECER Inc.

5521 Meadowbrook Industrial Court
Rolling Meadows - IL 60008 - USA
t: +1 (847) 925-1238
serviceamerica@comecer.com

COMECER Netherlands B.V.

NL-8501 XC - Joure - The Netherlands
t: +31 (0) 513 41 69 64 - f: +31 (0) 513 41 69 19
infonl@comecer.com

COMECER India Pvt Ltd

Office No.112-113, Veena-Beena Arcade, Gurunanak Road
Bandra (West) - Mumbai - India - 400050
t: (+91) 22 26423421 - f: (+91) 22 26423412



www.comecer.com

Distributed by: