

The Console GUI is designed to show the protocol information quickly and easily.

Vision friendly colors and sizes chosen as another safety feature of this new injector.



Setup screen to support quick and accurate input.



The GUI includes all necessary data on one screen image.



Injection Results screen shows injected volume in chronological order.



Console with touchscreen operation. Color changes based on mode of operation.



Dual Functionality Manual Knobs



Organic EL display shows syringe remaining volume.

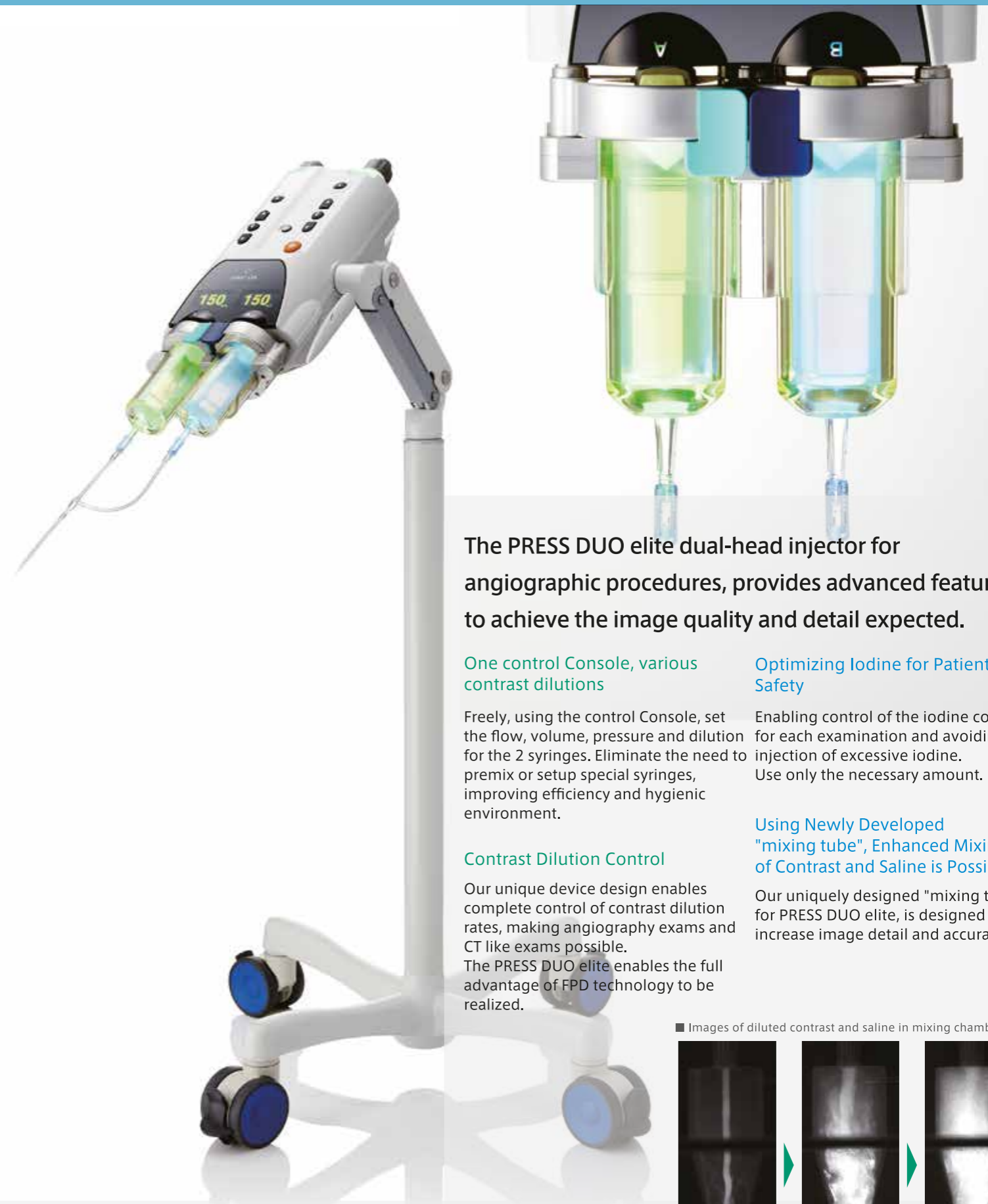

The PRESS DUO elite dual-head injector for angiographic procedures, provides advanced features to achieve the image quality and detail expected.

One control Console, various contrast dilutions

Freely, using the control Console, set the flow, volume, pressure and dilution for the 2 syringes. Eliminate the need to pre-mix or setup special syringes, improving efficiency and hygienic environment.

Contrast Dilution Control

Our unique device design enables complete control of contrast dilution rates, making angiography exams and CT like exams possible.

The PRESS DUO elite enables the full advantage of FPD technology to be realized.

Optimizing Iodine for Patient Safety

Enabling control of the iodine content for each examination and avoiding the injection of excessive iodine. Use only the necessary amount.

Using Newly Developed "mixing tube", Enhanced Mixing of Contrast and Saline is Possible

Our uniquely designed "mixing tube" for PRESS DUO elite, is designed to increase image detail and accuracy.

Images of diluted contrast and saline in mixing chamber

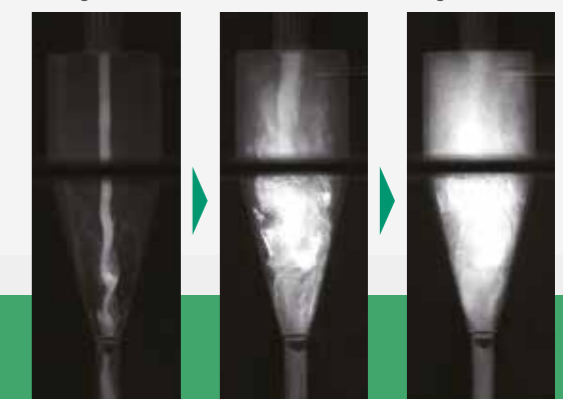

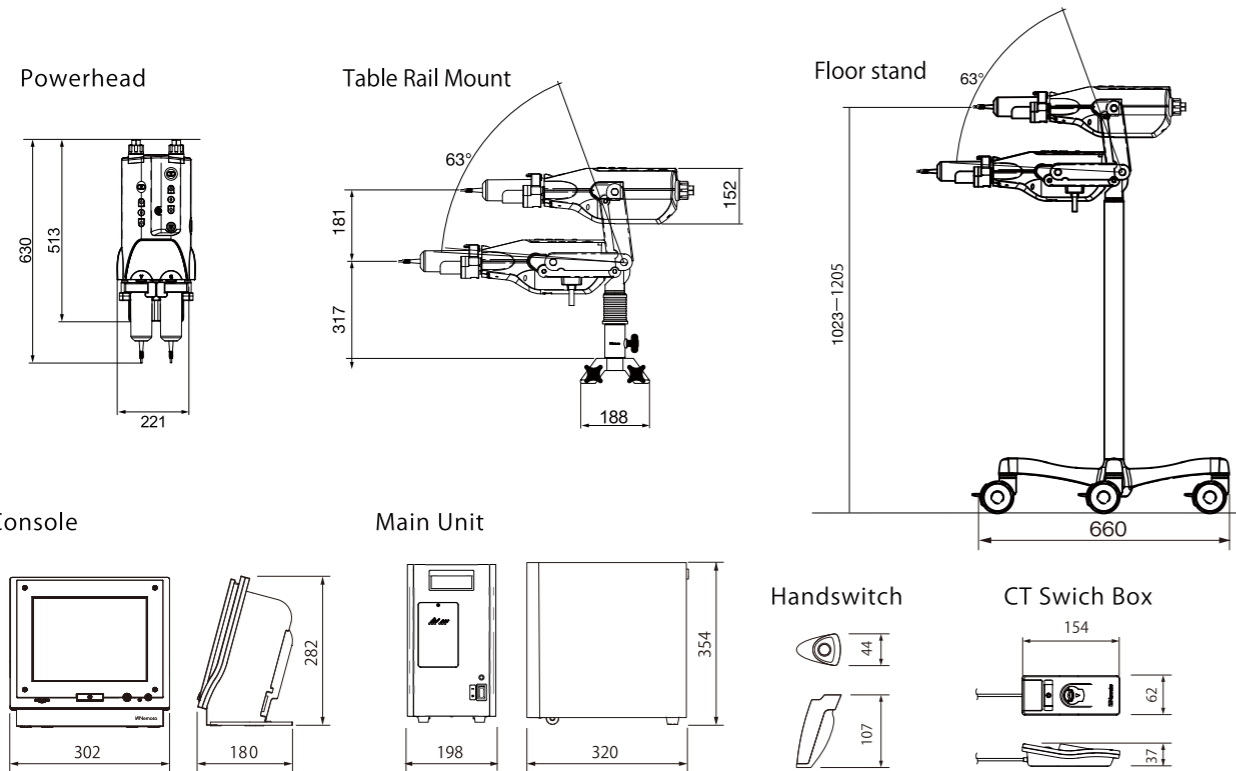

PRESS DUO elite

Dual-head Contrast Delivery System for Angiographic + CT Imaging

Press Duo elite

Standard Specifications

* A: Contrast agent B: Saline

• Flow Rate	0.1~30.0mL/sec (0.1mL/sec step)
• Volume	0.1~99.9mL (Setting Unit: 0.1mL)
• Pressure Limit	50~1200psi (400~8200kpa)
• Inject Delay	0~99.9 sec
• X-Ray Delay	0~99.9 sec
• Rise Time	0~9.9 sec
• Injection Pattern	A, A+B, A+B→A+B, A+B→A, A→A+B
• Protocol Memory	240 protocol
• Integrated Volume display	Yes,
• Injection Results Display	Yes, (Cases 50)
• Syringe Heater	Yes, 36°C ± 5°C

Angio(A+B) Mode Programming Range

• Flow Rate	A-side: 0.1~30.0mL/sec (0.1mL/sec step) B-side: 0.1~10.0mL/sec (0.1mL/sec step)
• Volume	0.2~99.9mL (Setting Unit: 0.1mL)
• Dilution Rate	Dilution percentage: 10-90 Dilution ratio: 1:9-9:1

CT Mode Programming Range

• Flow Rate	0.2~10.0mL/sec (0.1mL/sec step)
• Volume	0.2~150.0mL (Setting Unit: 0.1mL)
• Pressure Limit	50~300psi (400~2000kpa)

Angiographic Contrast Delivery System

Electrical Specifications

• Voltage	AC115/230V	• Protection Class	Class I
• Power Consumption	1050VA	• Protected Level	Type CF
• Frequency	50/60Hz	• Activation	Electromechanical drive

Safety Mechanisms

• Flow Rate Monitoring	• Syringe Placement Monitoring
• Overvolume Monitoring	• Injection Process Monitoring
• Over Pressure Monitoring	• Emergency Stop Buttons

Standard Injection Functions

• Dilution Injections (simultaneous injections)
• Quick Purge (auto air vent)
• Quick Return
• X-Ray System Synchronization
• Injection Results Display
• Angio Mode • CT Mode (Switch Box)

Option

- Table Rail Mount

Syringe

- NEMOTO Disposable syringe 150mL

Weight

- Powerhead: 11.1 kg • Console: 5.7 kg • Main Unit: 16.0 kg